

AD160 - 12-Bit, 60 MS/sec, PC/104 Data Acquisition Card

06/06/2006

Chase Scientific Company - *Innovators in Embedded Test & Measurement*

FEATURES

- 1 Channel, 60 MS/sec, 12-Bit Digitizer
- PC/104, 5V Only with Low Power Mode
- 1 MegaSamples/ch standard (expandable to 8M)
- Trigger on external TTL input, or software (auto-trigger, single shot)
- Standard +/-0.5V input range. Custom +/- 0.25 to +/-2.0V Range (option 3)
- Software Programmable Clock Rate of 60MHz, 30MHz, 15MHz, 7.5MHz
- Programmable Memory Size from 128 samples to 8 Msamples in powers of 2
- Software Drivers in C for DOS and Linux with example code.

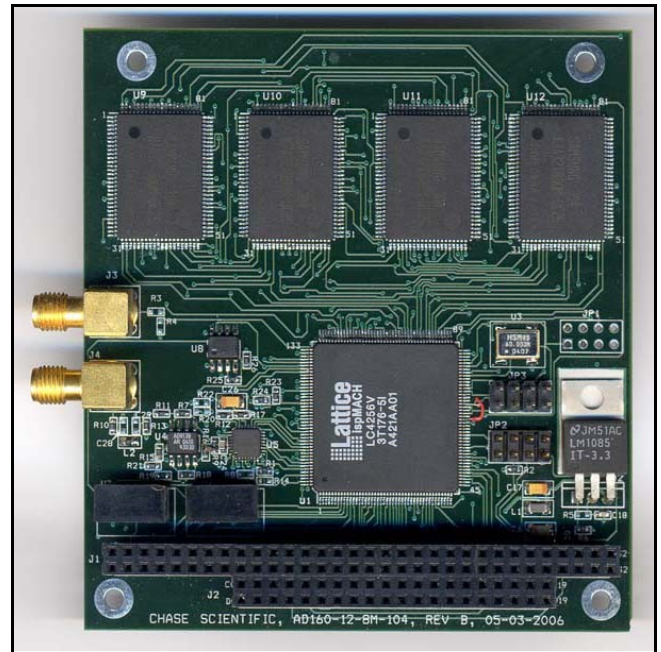

APPLICATIONS

- Portable Test and Measurement Systems
- Ultrasonic Testing
- CCD Imaging, Infra-red Imaging
- Spectroscopy
- Cellular communications
- Industrial Radar

DESCRIPTION

The AD160-12-1M-104 features one 12-bit, high speed singled ended analog input channel on a standard PC/104 module. The analog input is connected through an SMA connector and terminated into 50 ohms. Input bandwidth is limited to 20 MHz by default for the user's convenience, although input bandwidth can be set as high as 100 MHz (see option 2).

Triggering

The board is designed to be edge triggered by TTL input or by software. The user can also set the polarity of an external input trigger.

Timing and A/D Conversion

Timing is managed by a on-board controller referenced

to a crystal oscillator. The clock frequencies available are divided down in powers of 2 from the master clock to provide 60MHz, 30MHz, 15MHz, and 7.5MHz software programmable Sampling Rates.

Memory

The AD160 comes with 1MegaSamples of memory with option for 8 MegaSamples.

Software Drivers, User Interface

Source code is available for DOS and Linux. Call Chase Scientific for drivers for other operating systems.

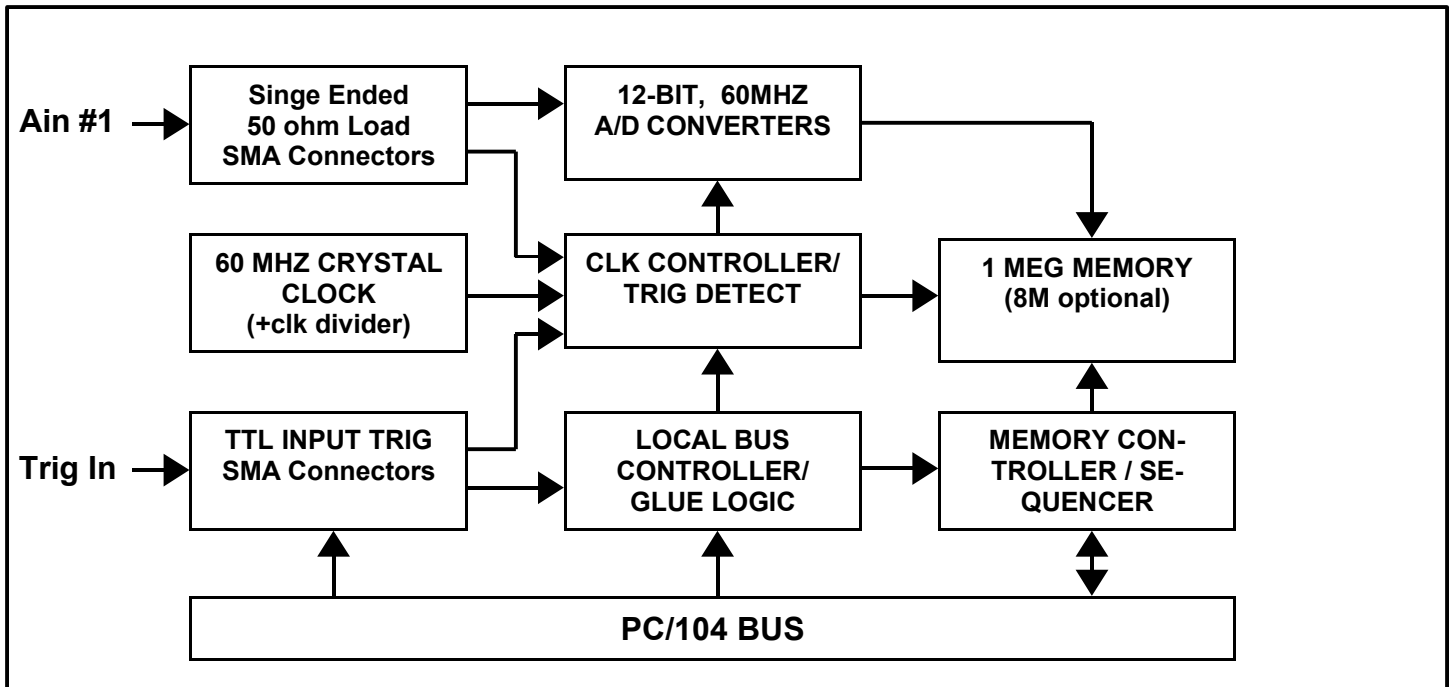

AD2100 BLOCK DIAGRAM

SPECIFICATIONS

Analog Input	(1) singled-ended into 50 ohms SMA
A/D Resolution	12-bit (1 part in 4096)
Conversion Rate	60 MS/s maximum, 7.5 MS/s min.
Sampling Method	Simple A/D
Acquisition mode	One Shot
Input Bandwidth	20 MHz Standard
Input Ranges	
Fixed Gain	+/- 0.5 Volts
Fixed Gain Chg	User Specified (+/- 0.25V to +/-2V)
Input Coupling	DC
Maximum Input Voltage	+/- 6 V
Max Samples (total)	1048576 Standard (8388608 optional)
Prog. Memory Sizes	Software selectable segment sizes of 128, 256, 512, ... 8388608.
Timebase	
Standard	Software selectable at 60 MHz, 30 MHz, 15 Mhz, 7.5 MHz.
Trigger	
Location	Start of Segment
Sources	External TTL, Software
Slope	Positive or Negative
Coupling	DC, TTL levels

GENERAL

Power Supply (60MHz)	+5V @ 410mA (Ave. Running) +5V @ 130mA (PWR_DWN)
Operating Temperature	-40 to +85 degrees C Standard
Operating Humidity	5% to 95% noncondensing

Size	Standard PC/104
Connectors	SMA

Option Summary:

Option 1:	2 Megasamples
Option 2:	100 MHz Input Bandwidth
Option 3:	Fixed Gain Change Request
Option 4:	Linux Drivers

<i>Model Number</i>	<i>Description</i>
AD160-12-1M-104	Basic 1-Ch, 60 MSPS w/1MEG Memory
Option 1	8 MEG Memory
Option 2	100 MHz BW
Option 3	Fixed Gain Change Req.
Option 4	Linux Drivers

The information herein is subject to change without notice from Chase Scientific Company. All marks and product names are property of their respective owners.