

DA12000 - 1CH, 2.0 GS/sec, 12-Bit PCI Arbitrary Waveform Generator

Chase Scientific Company - *Innovators in Embedded Test & Measurement*

Last Updated 7/12/2011

FEATURES

- (1) Chan, 2.0 GS/sec/chan, 12-Bit D/A resolution
- 4/16 MegaSamples Versions Standard
- Single mid-sized PCI card
- SFDR less than -45 @ 4 MHz - 700 MHz (typ)
- Full scale Trise/Tfall = 200 picoseconds (typ)
- Internal/External Master Clock, Trigger
- Programmable segmentation size, trig, looping, etc.
- (2) TTL marker outputs
- Free Software Drivers for Windows 98, NT, 2000, XP, Vista, Windows 7, and Linux.

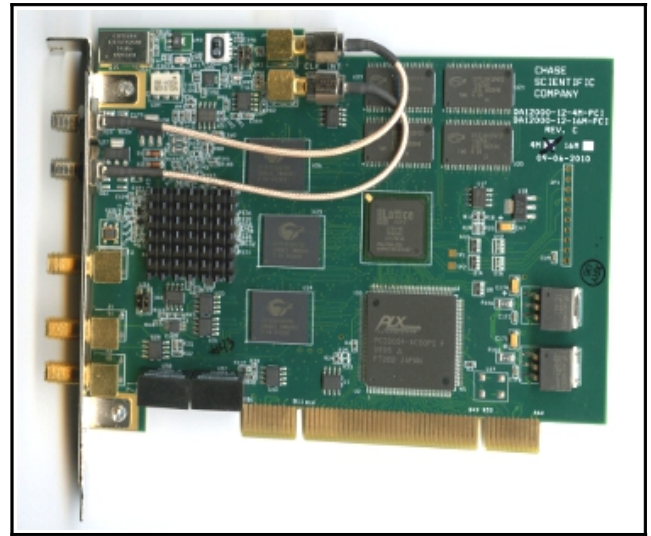

APPLICATIONS

- Radar Signal Generation and Testing
- Telecom / Data Communications
- Optical and Magnetic Storage Testing
- Arbitrary RF Signal Generation
- Wireless Communications Testing
- Real World Simulations
- Network Analysis
- Pulse Generation

DESCRIPTION

General

The DA12000 is one of the fastest PCI based Arbitrary Waveform Generators in the world and incorporates many advanced features such as programmable segment sizes, looping, and individual segment triggering. Since the data uploaded to the card can be arbitrary, almost any waveform that the user can imagine can be created. Whether it be random noise, a custom shaped pulse, a pure sine wave, a modulated subcarrier, or an encoded radar signature, the DA12000 will faithfully reproduce it.

The high speed D/A converter (DAC) runs off an internal 2.0 GHz master clock. An auxiliary board is available for synchronizing multiple boards, locking to reference clocks, and amplification. Because the DAC is only running at half of its maximum clock rate of 4.0 GHz, the signal quality is quite good. Most products in the AWG market are usually running at their maximum clock rates at reduced quality for their advertised rates.

Triggering

The DA12000 board is designed to be triggered by TTL input, pulsed PECL, or software command. For convenience looping can be set to automatic, in which case the a single segment waveform repeats indefinitely.

Memory

The DA12000 comes standard with 4 or 16 Mega-Samples of memory per channel.

Software Drivers, User Interface

A universal DLL and system drivers are available for Windows 98, NT, 2000, XP, Vista, and Windows 7. Linux drivers are available for 32/64-bit Linux 2.6xx. A simple debug Graphical User Interface (GUI) software for windows is included with the drivers for quick driver install verification and simple testing.

Chase Scientific Company

P.O Box 1487, Langley, WA 98260 Tel: 360-221-8455 Fax: 360-221-8457 Email: sales@chase2000.com Web: www.chase2000.com

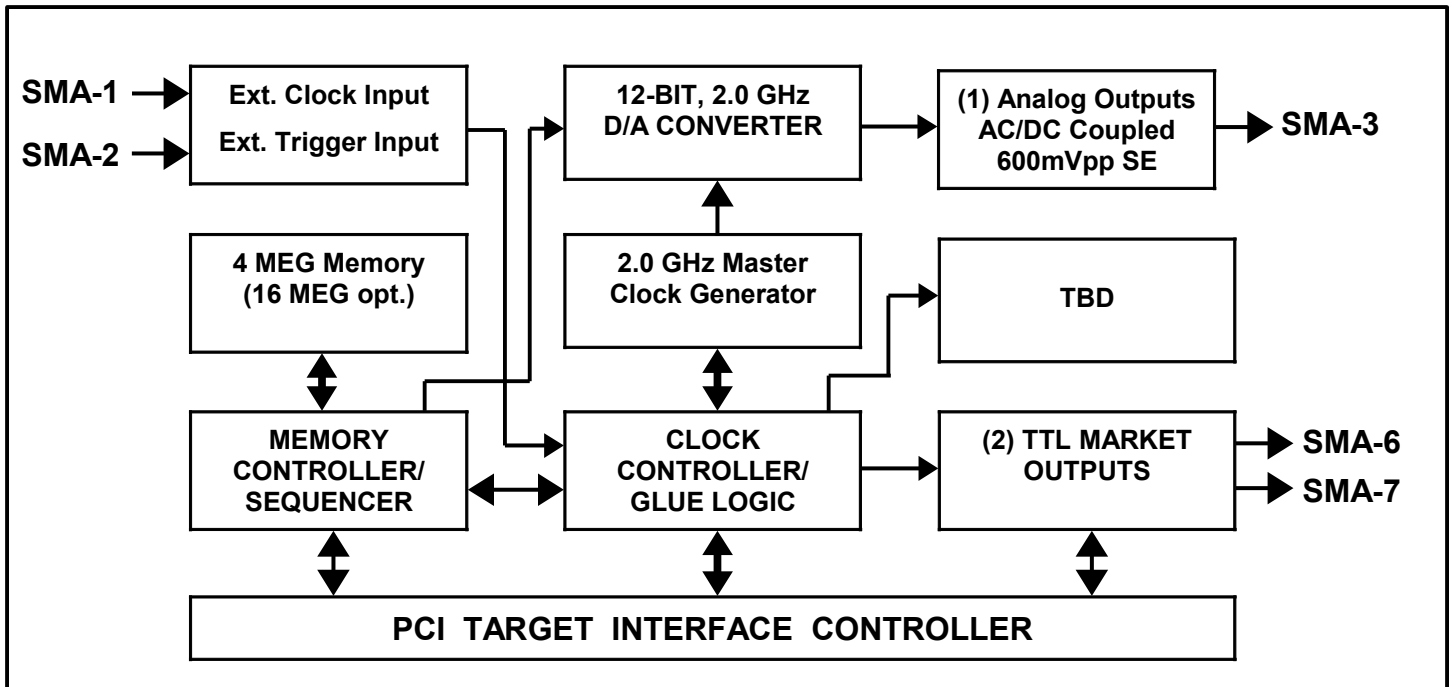

AD12000 BLOCK DIAGRAM

SPECIFICATIONS

ANALOG OUTPUT: Single Channel
(T=25°C unless otherwise stated)

Parameter	Conditions/other	Typical Values
Vertical Resolution	Fclk = 2.0GHz	12-Bit (1 out of 4096)
Output Impedance		50 ohms
Amplitude (See Attenuator Option for Programmability)		
Fixed output	Fclk = 2.0GHz	600 mVpp typical single-ended into 50 ohms (SMA connectors)
Rise Time (10-90%, no filters)		200 psec typical into 50 ohms
Fall Time (10-90%, no filters)		200 psec typical into 50 ohms
Internal Clock Jitter		<2 psec typical
Delay between trigger and output		TBD output clocks +/- 1clk
SFDR (Spurious Free Dynamic Range)		
4 MHz < Fout < 667 MHz, Fclk = 2.00 GHz		< -45 dB Typical
Internal Clock Rate Generator		
Frequency range		Fixed at 2.0 GHz
Resolution		N/A
Stability	T = 0°C – 70°C	+/- 100 ppm
Memory		
Waveform	Base Model	4 MWords x 12-Bits
	Maximum RAM	16 MWords x 12-Bits
# of User Segments		1 to 64K segments (max)
Segment Size Range		64 Words up to total memory,
Segment Resolution		64 word resolution
Maximum Segment Loops		16K
DIGITAL OUTPUTS:		
(1) TTL Marker	Fclk/4 resolution, 50 ohms output impedance	
DIGITAL INPUTS:		
High Speed Clk Input	50 ohms SMA inputs: 250 MHz, 500 MHz, 1.0 GHz, and 2.0 GHz, AC coupled.	
TTL Trigger Input	Rising Edge Retriggerable SMA connector, DC coupled TTL/PECL.	

ENVIRONMENTAL (DA12000)

Temperature

Operating	0°C to 50°C Ambient
Non-operating	-40°C to 85°C

Humidity

Operating	20% to 80% (no condensation)
Nonoperating	5% to 95% (no condensation)

Power

+5V	4.5 Watts Typical Active or Not Active
+3.3V	8.7 Watts @ 4 MWords Typical Active
	10.4 Watts @ 16 MWords Typical Active

Size

DA12000 Card	(1) Half Size 32-bit Standard PCI card
--------------	--

ORDER INFORMATION

Model Number	Description
DA12000-12-4M-PCI	Base 1-Ch, 2.0 GSPS w/4MEG Memory
DA12000-12-16M-PCI	16 MEG Memory

* Free Drivers for Win98/NT/XP/Vista/7 & Linux(TBD)

The information herein is subject to change without notice from Chase Scientific Company. All marks and product names are property of their respective owners.

Chase Scientific Company

P.O Box 1487, Langley, WA 98260 Tel: 360-221-8455 Fax: 360-221-8457 Email: sales@chase2000.com Web: www.chase2000.com