

300 MSPS, 4-Ch, 12-bit, PCI Arbitrary Waveform Generator

Chase Scientific Company - *Innovators in Embedded Test & Measurement*

11/10/2004

FEATURES

- 300 MS/s, 12-bit vertical resolution
- Up to (4) analog outputs at 2Vpp
- Single mid-sized PCI compliant card
- SFDR less than -50 dB at 100 MHz
- Full scale Trise/Tfall = 2.5ns typical
- Program up to 32K independent segments
- Program up to 16K loops/segment
- 1 MEG memory standard on each channel
- (1) TTL marker outputs standard
- (1) TTL trigger input
- (1) External Clock input
- SMA Connectors on all signals
- Software Drivers for Windows 95, 98, NT, 2000, XP.

DESCRIPTION

The DA4300 is the fastest PCI based Arbitrary Waveform Generator in the world with 4 analog output channels. The DA4300 incorporates advanced features such as programmable segment sizes, up to 32K programmable segments, and programmable loop counts from 1 to 64K (plus continuous). It also includes 1 MegWord of memory behind each channel. Using the standard PCI architecture, the DA4300 provides orders of magnitude faster upload rates than GPIB.

Extendible

Although the DA4300 is feature rich, you can extend this card by using a super stable and programmable external clock source such as the CG400 with 0.2 Hz resolution and 1PPM stability, or simply add up to (4) cards to a PC and get 16 high speed arbitrary channels, all synchronized. Also, you can call Chase Scientific for customized configurations and for porting the DA4300 design to other form factors.

Memory

The DA4300 comes standard with 1 MW of sample memory on-board. Memory is accessed automatically



APPLICATIONS

- Radar design and testing
- Optical and Magnetic Storage Testing
- Advanced Ultrasound Design
- Video design, test, and production
- Network analysis
- Communications
- RF signal generation

when the user creates their data arrays and calls a simple software function provided by Chase. The DA4300 driver software manipulates the data segments (user arrays) and uploads them automatically to the card. Also, by allowing each segment the ability to loop independently, the effective amount of memory can be 1000's of times the physical memory.

Software Drivers, User Interface

A universal DLL is available for Windows 95/98/NT/2000/XP and Linux. Linux has grown in popularity and Chase has committed to this open platform. A simple debug Graphical User Interface (GUI) software is included with the drivers. Call Chase Scientific for drivers for other operating systems.

Ideal for Embedded Systems

The AD4300 is ideal for embedded applications where a benchtop instrument simply won't fit the space desired or will bust the budget for the project. It provides OEMs and system builders a way to develop smaller, more efficient (faster transfer rates), and less expensive solutions than any benchtop or tethered products using GPIB.

DA4300, 300 MHz Arbitrary Waveform Generator (PCI Version)

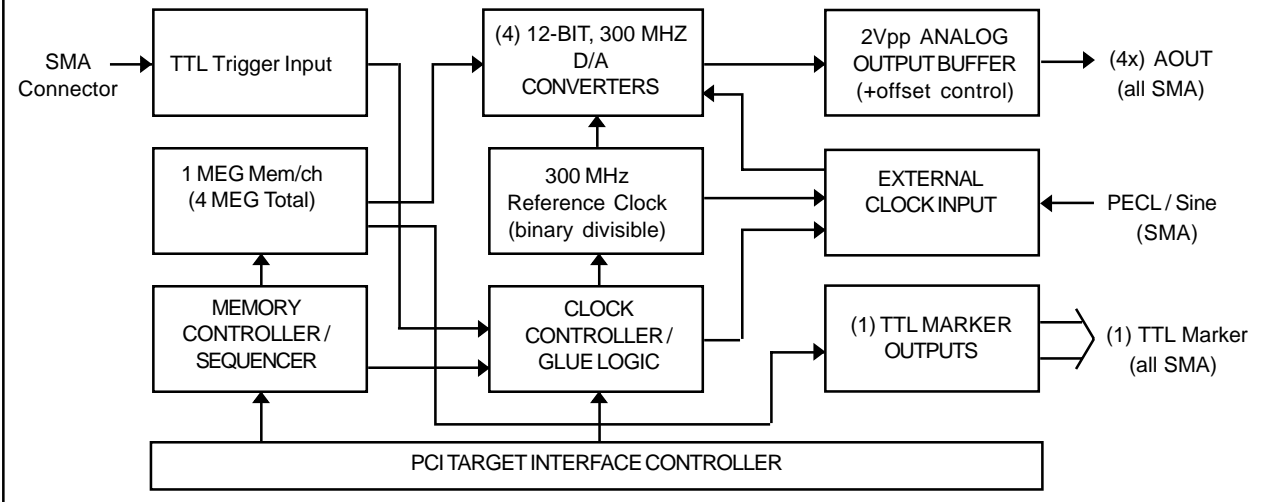

SPECIFICATIONS

ANALOG OUTPUT: (4) Analog Output Channels
(T=25°C unless otherwise stated)

| Parameter | Conditions/other | Typical Values |
|--|------------------------|---|
| Vertical Resolution | 0.23Hz ≤ Fclk ≤ 300MHz | 12-Bit (1 out of 4096) |
| Output Impedance | | 50 ohms |
| Amplitude (See Attenuator Option for Programmability) | | |
| Fixed output | 1MHz ≤ Fclk ≤ 300MHz | 2.0Vpp typical single-ended into 50 ohms (SMA connectors) |
| Offset | | |
| Range | | N/A |
| Resolution | | N/A |
| Rise Time (10-90%, no filters) | | 2.5 nsec typical into 50 ohms |
| Fall Time (10-90%, no filters) | | 2.5 nsec typical into 50 ohms |
| Internal Clock Jitter | | < 1 psec typical @ 1 sigma |
| Delay between trigger and output | | 20 output clocks +/- 1clk |
| SFDR (Spurious Free Dynamic Range) | | |
| Fout < 100 MHz, Fclk = 300 MHz | | < -50 dB Typical |
| Fout < 100 MHz, Fclk = 300 MHz | | < -60 dB Typical (2MHz Span) |
| Internal Clock Source | | |
| Reference Frequency | | 300.00 MHz |
| Software Selectable | | 300 MHz, 150MHz, 75MHz |
| Stability | T = 0°C - 70°C | +/- 20 ppm |
| Memory | | |
| Waveform | | 1048576 Samples x 12-Bits |
| # of User Segments | | 1 to 32K segments (max) |
| Segment Size Range | | 64 Words up to total memory, 16 word resolution |
| Maximum Segment Loops | | 16K |
| DIGITAL OUTPUT Markers | | |
| Number | | 1 TTL output |
| Timing Resolution | | Fclk/4 |
| Impedance Output | | 50 ohm |
| DIGITAL INPUTS | | |
| High Speed Clk Input | | 50 ohms SMA input: DC to 300 MHz |
| TTL Trigger Input | | Used to initiate memory sequence; One-shot, retriggerable, software programmable, SMA connector |

PROGRAMMABLE ATTENUATOR (Option 1)

| Parameter | Conditions | Typical (unless stated) |
|------------------------|------------|------------------------------|
| Frequency Range | -3dB BW | DC - 500 MHz |
| Amplitude | | |
| Range | | 0 dBm to -30 dBm in 64 steps |
| Resolution | | 0.5 dBm |
| Insertion Loss | | 1.3 dBm typical |

ENVIRONMENTAL (DA4300)

| | |
|---|-----------------------------------|
| Temperature | |
| Operating | 0°C to 70°C Ambient |
| Non-operating | -40°C to 85°C |
| Humidity | |
| Operating | 20% to 80% (no condensation) |
| Nonoperating | 5% to 95% (no condensation) |
| Power | |
| +5V | 2.5 W* |
| +3.3V | 8.4 W* |
| +12V | 2.6 W* |
| -12V | 1.2 W* |
| Total = 14.65 Watts. (*using worst case waveform on all channels) | |
| Size | |
| DA4300 Card | (1) Mid-size 32-bit std. PCI card |

ORDERING INFORMATION

| Model Number | Description |
|------------------|---|
| DA4300-12-1M-PCI | 4-ch, 300 MSPS, 12-bit AWG |
| | |
| <i>Option 1</i> | <i>Programmable Attenuators</i> |
| <i>Option 2</i> | <i>Custom Amplitude Range</i> |
| <i>Option 3</i> | <i>Linux Drivers (2.2x, 2.4x, 2.6x)</i> |

The information herein is subject to change without notice from Chase Scientific Company. All marks and product names are the property of their respective owners.